

Specification 5555

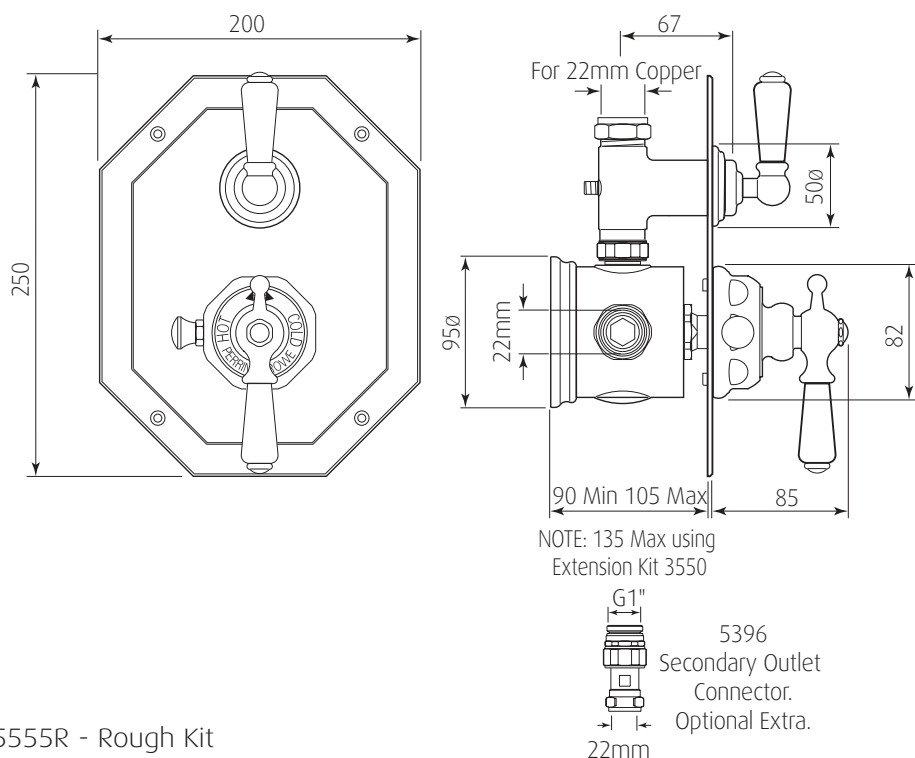

Concealed Dual Control Thermostatic Shower Mixer

- Wax capsule thermostatic cartridge with 1 second supply failure response ●
- Separate temperature and flow levers ● 1/4 turn ceramic disc flow control ●
- Adjustable temperature safety override stop (pre-set to 38°C) ●
- G 3/4" inlets fitted with non return valves and strainers ●



5555R - Rough Kit

5555T - Trim Kit

Packed Weight: 6.4Kg
Rough Kit 3.8Kg
Trim Kit 2.7Kg

Temp Range:

Min 18°C / 52°F
Max 49°C / 118°F

Temp Stability:

± 1°C / ± 1.8°F

Max Inlet Temp:

82°C / 180°F

Recommended working pressure:

Min 0.5 bar / 7psi
Max 5 bar / 75 psi

Specification 5555



Concealed Dual Control Thermostatic Shower Mixer

- Wax capsule thermostatic cartridge with 1 second supply failure response ●
- Separate temperature and flow levers ● 1/4 turn ceramic disc flow control ●
- Adjustable temperature safety override stop (pre-set to 38°C) ●
- G 3/4" inlets fitted with non return valves and strainers ●

Where * Indicated Specify Colour.

