

# Specification 5382 5392

## Hook Riser

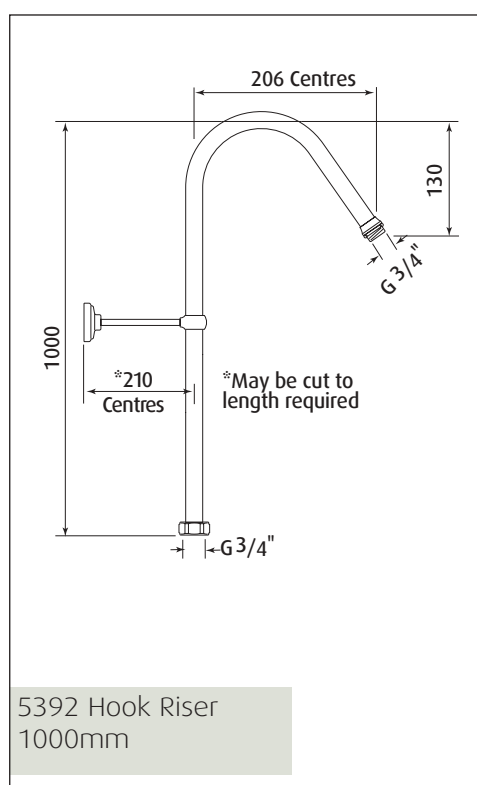
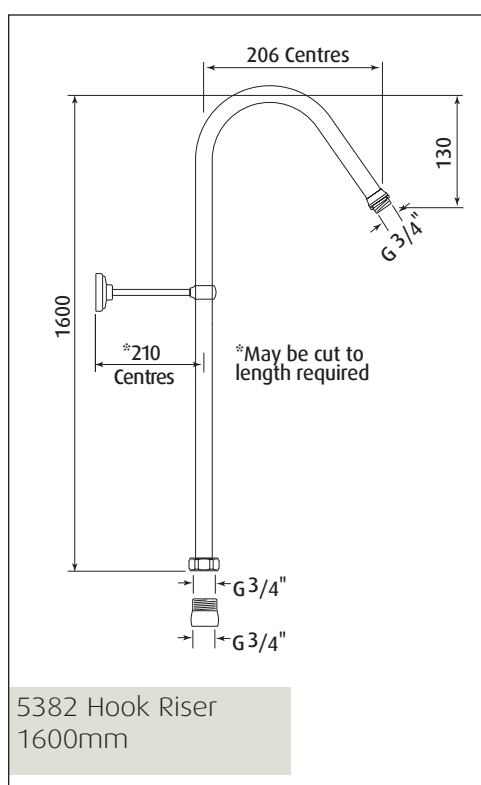
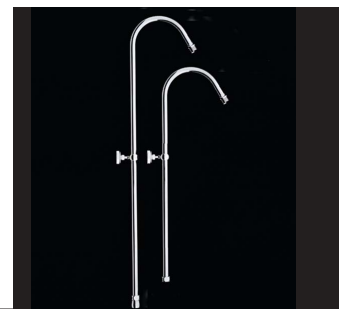

**Packed Weight:** 5382 3.1Kg  
5392 1.9Kg

### Temp Range:

Min 1°C / 34°F  
Max 85°C / 185°F

### Recommended working pressure:

Min 0.5 bar / 7psi  
Max 5 bar / 75 psi

# Specification 5382 5392



## Hook Riser

Where \* Indicated Specify Colour.

